

No. 108 Internal Tubing Cutter

Capacity: 1 1/4" through 2" I.D.

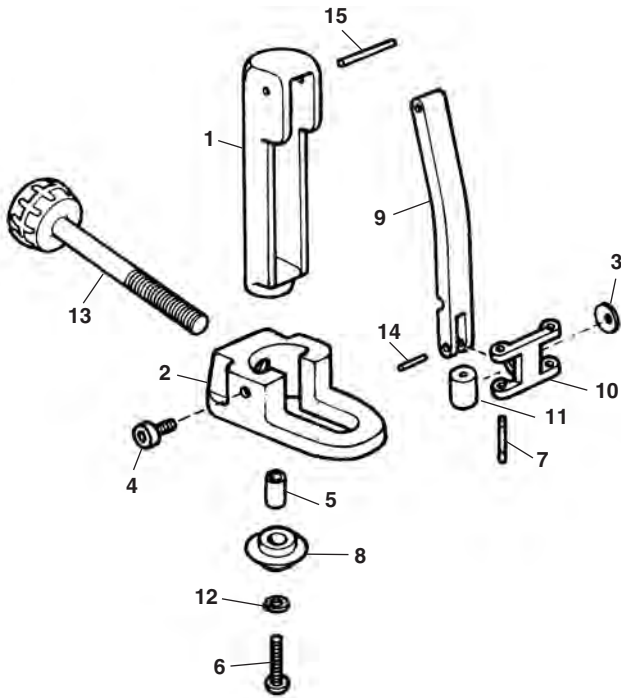

**NOTE: Order parts by Catalog Number only.
DO NOT order by Reference Number.**

Ref. No.	Catalog No.	Description
—	83240	108 Tubing Cutter
1	83245	Housing
2	83250	Guide
3	83280	Washer
4	87855	Cap Screw
5	33895	Sleeve
6	33910	Screw
7	33960	Pin (2)
8	33170	Cutter Wheel
9	83255	Roller Pivot Bar
10	83260	Roller Cage
11	83265	Roller (2)
12	83275	Washer
13	83270	Feed Screw
14	34720	Roll Pin
15	41500	Roll Pin

No. 109 & 109-P Internal Tubing Cutter

Capacity: 2 1/2" through 4" I.D.

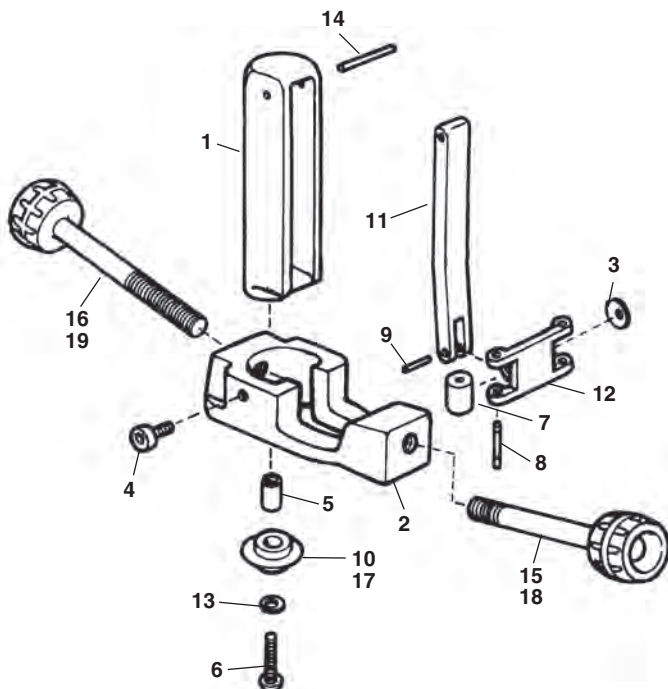

Ref. No.	Catalog No.	Description
—	83290	109 Tubing Cutter
—	83295	109-P Tubing Cutter
1	83300	Housing
2	83305	Guide
3	92150	Washer
4	87855	Cap Screw
5	33895	Sleeve
6	33910	Screw
7	33915	Roller (2)
8	33920	Pin (2)
9	32475	Roll Pin
10	33170	Cutter Wheel (Copper)
11	83310	Roller Pivot Bar
12	83315	Roller Cage
13	83275	Washer
14	83325	Roll Pin
15	83320	Handle (for Tubing)
16	83270	Feed Screw (for Tubing)
17	33180	Cutter Wheel (Plastic)
18	87460	Handle (for Plastic)
19	87455	Feed Screw (for Plastic)